

IP Power 9828-P

User Manual



Version: 1.00
Firmware Version: 1.31
Date Released: Dec. 2022

Warning: Any changes made to this equipment without permission may cause damages to the device!

IMPORTANT NOTICE

1. IP Power 9828-P was designed for indoor use, we carry no responsibility for possible damages caused by outdoor use, especially in the rain.
2. Please use the power adapter provided by the dealer, we carry no responsibility for the possible damage from using power adapters not provided by us. .
4. Do not shake the IP Power 9828-P in any fashion
5. Please contact the dealer If IP Power 9828-P is not working properly.

Copyright © 2022 All rights reserved. No part of this publication may be reproduced, stored in a retrieval system, or transmitted in any form or by any means, electronic, mechanical, photocopying, recording or otherwise, without the prior written consent of us.
All trademarks and products mentioned in this document are the properties of us.

Table of Content

1.Introduction	5
2.Product Information.....	6
2.1 Features	6
2.2 Minimum System Requirements	7
2.3 Package Contents.....	7
2.4 Interface Description.....	8
3.Setting up your device.....	9
3.1 Before Starting.....	9
3.2 Hardware Connection	9
3.3 Software Installation	10
3.3.1 LAN connect by IP search software “ IPEDIT “	10
3.3.2 Internet Setup	13
3.3.3 Using IP Service	14
4. Web Interface.....	15
4.1 Connect to your device	15
4.2 Top Column	17
4.2.1 Device name	17
4.2.2 Column Display	18
4.2.3 Date and Time.....	19
4.2.4 Current Usage & Temperature	20
4.3 Power Control	21
4.3.1 Control.....	21
4.3.2 Schedule.....	28
4.3.3 Ping.....	30
4.3.4 M2M mode	34
4.4 Network.....	37
A. Static Mode (fixed IP).....	37
B. DHCP Mode.....	38
C. PPTP Mode	39
D.UPNP Mode	39
4.5 Application Settings.....	40

4.5.1 Email.....	40
4.5.2 DDNS	45
4.5.3 Communication.....	46
4.5.4 IP Service.....	48
4.6 System Setting.....	51
4.6.1 Management	51
4.6.2 System Information.....	54
4.6.3 System Log	54
4.6.4 Firmware.....	55
5.Other ways to control	56
5.1 CGI HTTP Commands	56
5.2 Telnet Control.....	58
6. FAQ :	59

1.Introduction

IP Power 9828-P is a new generation of the Power Distribution Unit (PDU) & Remote Power Control (RPC) system which **add "Active Spike Filter Design"** in the hardware design and make the system with higher grade stability.

With embedded web server and **HTTPS** protection , 9828-P supports higher grade security as working on Internet. User can control power easily and more safely through the web browser in Windows, Android or iOS system , like Internet Explorer (IE) / **Edge** , Google Chrome , Safari web browser or control through APP in Android or in iOS system .

With 2 buttons on device front , it allows user to direct control manually to each port ON/OFF with fingertip without web browser / APP , also allows remote control power on/off up to 2 **separate** devices via network .

As support **SSL & SNMP**, user can use public email like Gmail / Hotmail / Yahoo Mail to get the email as the ON/OFF status changed . User can also **control** by **e-mail** without doing port forwarding / port mapping and search the other IP Device in webpage directly and quick .

9828-P supports **Auto Ping, Time Scheduler** which is more suitable for factory / commercial / office / home automation. User can get the device status in LOG information or in remote IP address which sent to get LOG message from 9828-P (SYSLOG) . .

For system integrator, there are several popular developing tolls like HTTP/CGI command , **Telnet, SNMP**, Modbus TCP/IP & BACnet TCP/IP.

The various applications of the 9828-P includes:
Power Management, Server Management, Internet Controllable Timer, System Integration, Remote Power Control in Remote locationsetc.

User Friendly . Convenience & Powerful ,



2.Product Information

2.1 Features

1. 2 ports Remote power controller for power On, Off and Reboot by the magnetic Latching Relay (See note)
2. Add " Active Spike Filter Design " for higher stabilities.
3. **2 Buttons Control** : Direct manual hardware control each outlet without working on Web browser .
4. 2 Network ports (RJ45) : one for Internet and another for HUB (by pass)
5. Current meter for total Amp (2 ports total) .
6. Web Server built-in design, directly control by web browser in Windows , **Android or iOS** system like Internet Explore (IE) , Google Chrome and so on .
7. Support **HTTPS** , SSL , TCP/ IP , DHCP, DDNS , SMTP , **Telnet** , **SNMP** , **Modbus/TCP and BACnet/IP** .
8. **SYSLOG** : Support Log function & send to assign IP address
9. Time Schedule - can pre-set a suitable time to turn power on / off automatically .
10. **Auto Ping** for network control & segment management automatically
11. High grade components for long stability and performance
12. **Back Up** for quick setup for multiple devices like Time Schedule, Network Setting.
13. Support public e-mail -- @gmail.com , @yahoo.com , @hotmail. com.....etc.
E-mail Control & Advice :
 - Receive e-mail with IPs device boot up.
 - **POP3 Control**–Control each outlet ON/OFF via E-mail. No need to do Port Forwarding .
14. Specific software developed by Aviosys and provided free of charge :
 - SDK Available : HTTP Command
 - Windows software " IP Power Center " : Control Multiple Aviosys IP Power devices in one software
 - CNT software (Cross Network Technology)- allows user eliminate set up work on any Router without port forwarding , simply Plug & Play .
 - **Support MQTT protocol.**
15. Support APP for Android or iOS system :
 - **Android APP** -- name "IP Power " free download in Google Play .
 - **iOS APP** -- name "IPPOWER+ " free download in Apple App Store



Specification

- Power input: 15A / 90-120VAC, 10A / 210-240VAC, 50-60Hz.
- Maximum loading of each output: **10A (9828-P-S) or 15A (9828-P-T)**
- Maximum of Total loading: **10A (9828-P-S) or 15A (9828-P-T)**
- Dimensions: 195 x 100 x 35 mm (L x W x H)
- Weight: 560g
- Enclosure – Matel case in deep Gray color
- Operation **Temperature**: -10 ~ 60 °C or 14 ~140(°F)

- Note : Use the **magnetic “ Latching Relay ”** , operation temperature can go up to 85°C (185 °F) with MTBF 100K times , longer electrical life expectancy.
It keeps device operating temperature at low state and maintain therewithout going higher even all 2 port at ON state simultaneously , plus lower power consumption for **energy savings** purpose.

2.2 Minimum System Requirements





- Network & Web Browser & Internet Connection
- Ethernet Cable & Power Cord

2.3 Package Contents

- 9828-P Unit
- Online CD note : www.aviosys.com/cd

2.4 Interface Description

Outlook

	
Front :	
Switch 1 & 2 for Buttons Control outlets	<p>The two buttons are for emergency safety switch The default function is Toggle (Switch ON / OFF) .</p> <p>But the buttons function can be setup as 6 modes : OFF, ON, Shut down on Lan , Wake on Lan , Toggle or None . Disable, . Please go to webpage “ I/O Control “ → “ Control “ → “ Advanced ” → “ Emergency safety switch setting ”</p>
Main Net 1	LAN 10/100 Mbps network for Internet
Net 2	HUB for bypass the signal of Net 1 (LAN 10/100 Mbps network)
LED 1 & 2	Display the 2 outlets as ON or OFF
<p>● IP9828-P-S</p> 	<p>● IP9828-P-T</p> 
Interface from Left to right :	
Outlet 1 & 2	<p>9828-P-S : IEC320 socket , 10A / 240VAC 9828-P-T : NEMA socket , 15A / 100VAC Max. Current : 10A / 240VAX or 15A / 100VAC (for total two ports / single port)</p>
Power input	15A / 90-120VAC, 10A / 210-240VAC, 50-60Hz.
Power Switch	Turn ON / OFF the power of 9828-P devices.
	
Right Side:	
Reset	<p>Please keep pressing the button for 7 seconds and then release .You will hear 3 short beep sound which show the reset Successfully . After reset , all the settings , like IP, password and so on , will be back to Default.</p>

3. Setting up your device

3.1 Before Starting

*Before setting up the device make sure of the following:

- 1.) All the package contents are all included if anything is missing please contact the dealer where the device was purchased from.
- 2.) Check the power input cable is working correctly.
- 3.) Check all cables to make sure there are no problems with it.

3.2 Hardware Connection

Before hardware connection, please make sure that there is no more than 2 network card (include dynamic network card) . If there are more than two network card in your PC. You may not get the IP address of 9828-P

The default setting of 9828-P `s IP is by DHCP assigned by Router. The connection sequence is different as connect to Router or connect to PC directly. Please refer following procedure :

A. 9828-P ----- Router ----- PC (with Web browser)

- 1.) Connect the Ethernet cable (RJ45) to the 9828-P to your local area network.
- 2.) Then connect the power cable into the power input port of the 9828-P.
- 3.) Connect the device that you would like to control to the output plug on the top of the 9828-P.
- 4.) Switching the power source to ON status , this switch is located at the rear of 9828-P.
- 5.) After power on for around 45 seconds , there is a short beep sound for 9828-P which means the system reboot successfully

B. 9828-P ----- PC (with Web browser)

If you select to connect to PC directly, please connect the RJ45 cable to 9828-P after 1 minutes as power on of the 9828-P device . power hear the beep sound of 9828-P DO NOT connect the RJ45 as power ON

If you select to connect to you PC to 9828-P directly :

- 1.) Connect the power cable to 9828-P and press the power switch to ON
- 2.) After 9828-P power on for around 45 seconds , there is a short beep sound for 9828-P which means the system reboot successfully
- 3.) Then Connect the Ethernet cable (RJ45) to the 9828-P to your PC.
- 4.) Execute the software IPEDIT.exe to get the IP as **192.168.1.169**
- 5.) Please make sure the IP address of you PC is also 192.168.1.X / XX/XXX or you may not log in the 9828-P webpage in 192.168.1.169

3.3 Software Installation

Please go to our webpage www.aviosys.com/cd to get the software and manual of your product.

Under windows system, we offer two software :

1. IP Edit (Required to search IP address)
2. IP Power Center (For multiple IP Power devices control purpose)



- 1.) Select the IP Power 9828-P



- 2.) All the available downloads for the 9828-P will be shown

- 3) Download the required software – **IPedit.exe** - by clicking on the download button.



Then you can select to connect 9828-P.

3.3.1 LAN connect by IP search software “ IPEDIT “



IP Edit is a search tool designed to search, configure, or access the IP Power 9828-P from a localnetwork computer.

IP Power 9828-P Default Login / Password

Default IP: 192.168.1.169 (if there is no DHCP router assigned IP)

Default Login username : admin

Default Password: 12345678

Please use our IP Search tool "IPEDIT.exe " to get the IP address of 9828-P .

1.) In the local devices section user will see user device shows up if connection is correct.



Notice:

If can't see the IP in the area of Local Devices of IPEDIT.exe. Please check the following situation

1. **Boot up successfully:** Please reboot the 9828-P-P and check if there are 1 short beep after 1 minutes. This beep means the device boot up successfully . If not , the device may have issue.
2. **Network card:** Please check if there are more than two network card – include wire / wireless / dynamic - in the PC which used IPEIT software . IPEDIT only support single network PC, please disable the other network connection / functions.
3. **Anti Virus software / Firewall:** Please turn off the antivirus software firewall temporary.
4. **Connection:** Please make sure that the 9828-P is under same router with the PC used IPEDIT . It is fine to connect across multiple routers but it need to setup the MASK part which need some knowhow.

Default as DHCP status, 9828-P will auto get the IP address from user`s router by the suggest hardware connection as following

9828-P ----- Router ----- PC (with Web browser)

If there is no assigned IP to 9828-P by the connection, the 9828-P will change to FIX IP address :

- **Default IP:** 192.168.1.169 (While this is no DHCP apparently)

If can't see the IP in the area of Local Devices of IPEDIT.exe. Please check if use more than one network card (include dynamic network card) , disable the Firewall and Anti Virus software temporally and try again.

- 2.) Select the 9828-P device and the device information will pop up on the right.
- 3.) Check to see that the gateway IP and the IP Address (9828-P) match user current

network.If not, type in the correct information, then hit the “ Submit “ button to save changes.

For example:

If user has the following information regarding the 9828-P and user network

User PC Network :

Computer IP Address: 192.168.1.122 , **Gateway:** 192.168.1.1
Sub Net mask: 255.255.255.0 , **Port:** 80

User 9828-P in IPEDIT :

9828-P IP Address: 192.168.100.34 , **Gateway:** 192.168.100.1
Sub Net mask: 255.255.0.0 , **Port:** 80

Since the IP Address of the 9828-P is : 192.168.100.34

User will need to make sure that the first 3 segments of user 9828-P IP Address must match the first 3 segments of user gateway IP.

First 3 Segment of Gateway Address: 192.168.1.X

So user new IP Address for the 9828-P should be: 192.168.1.XXX

New Network Information

9828-P IP Address: 192.168.1.26

Gateway Address: 192.168.1.1 , **Local Computer IP Address:** 192.168.1.122
Sub Net mask: 255.255.255.0 , **Port:** 80

- 4.) Press the “ Rescan “ button to see if changes have been made.
- 5.) Double click on the device in the local device section and an IE web browser with the device login will pop up.
- 6.) Type in the default Login and IP Address to enter the device.

Default Login : admin , Default : 12345678

Notice :

* User can click " REF " in IEPDIT to auto search proper IP setting for 9828-P.
It will take few minutes to show the suggest wizard.

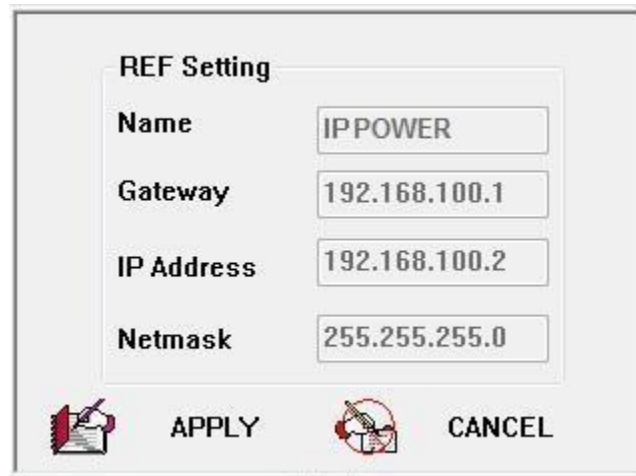
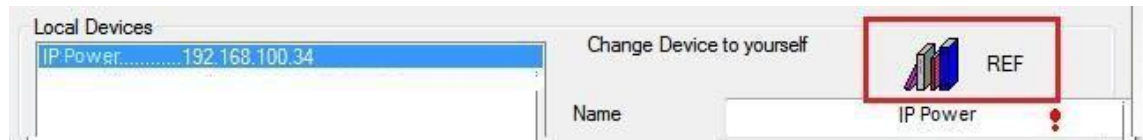

Please click " APPLY " as seeing the suggest wizard , click " yes " to ignore the remind message of IP being used and then type the Username and Password to change the IP setting.

Username : admin Password : 12345678

Notice :

Segment : The first 9 digits of the IP Address .

EX: The IP of user PC is 192.168.100.122. If the " Local IP Address " at Wi-Fi Info is 192.168.100.x (X can the value of 1~252) , user PC can get into the webpage of 9828-P .

Please press "Rescan " to search the router nearby again if can not see user router in the list.

3.3.2 Internet Setup

To connect the IP Power 9828-P on Internet, there are two ways

- Setup Port Mapping / Port Forwarding in your router. Please check your Router owner's manual .
- Use our own software " IP Power Center " : Please refer to the "IP Power Center " manual in software section of www.aviosys.com/cd

3.3.3 Using IP Service

IP Service is a function which allows user to search for the device easily without having to remember long complicated IP address. Instead, if user know the device's name of user's IPPower device and user can easily find IP Address with IP Service. **To log in the webpage of 9828-P on Internet , user still need to do the "Port Forwarding " in own router.**

Before using "IP Service ", please change the device name of user 9828-P to avoid similar name in Host Server.

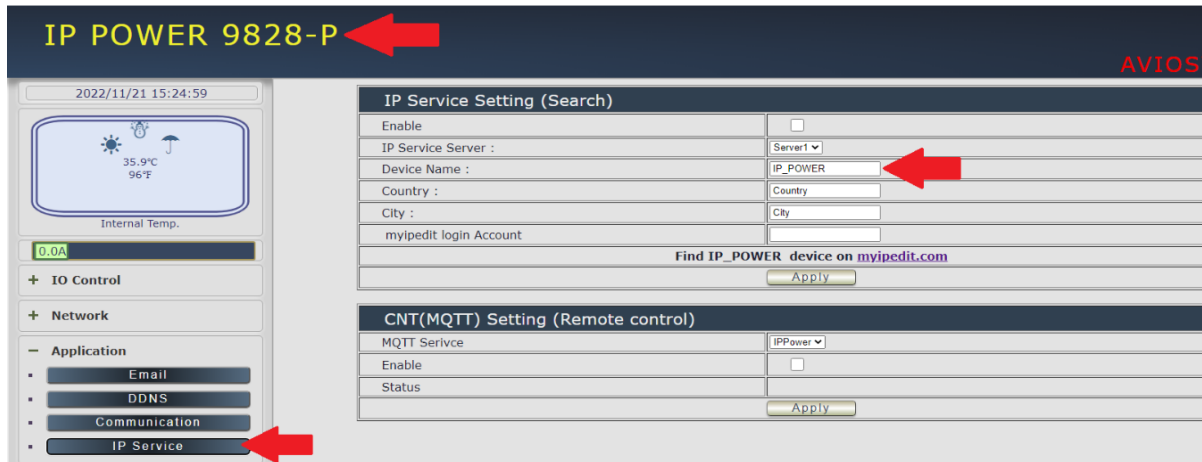

1.) Open IP Edit and select the server that user's 9828-P is designated to.

2.) Hit the Green Connect button on the top of IP Edit.

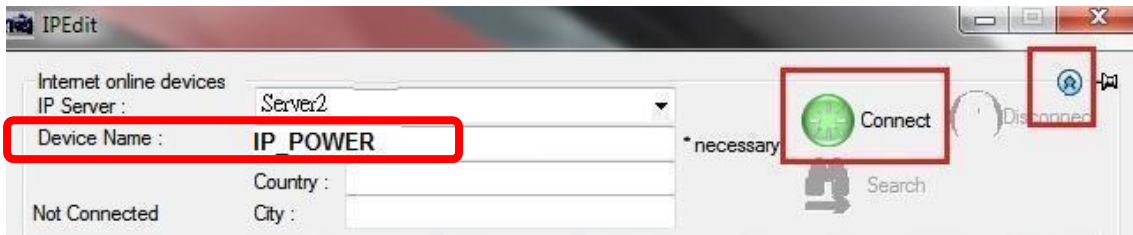

3.) Then type in the 9828-P Name that user have selected for the device and press the Search button.

4.) Find user device and double click on the screen and a IE window will pop up connecting to user device. **User device must be Port Forwarded for the login screen to appear.*

EX: The 9828-P device name as IP_POWER, and user can search the device easily :

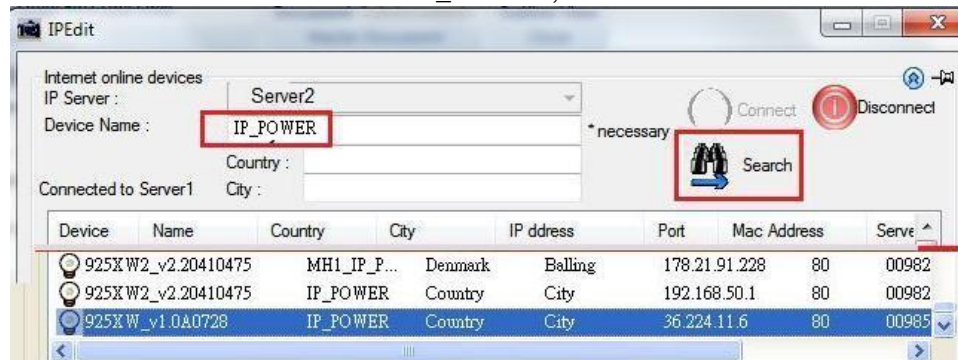

5.) After user has connected to user device, type in the Login and Password for user device

4. Web Interface

4.1 Connect to your device

Once the 9828-P has been setup correctly, log into the device.

First Option

- 1.) Go to IP Edit to find the device that is being used
- 2.) Double click on the device linked and an IE window will appear with the loading screen

Second Option

- 1.) Open Internet Explorer type in the IP Address of the device followed by the : sign.
For example: http:192.168.122.188:9258

192.168.122.188 – IP Address

- 2.) Once you have typed in the IP address of the 9828-P and it is ready to be worked.

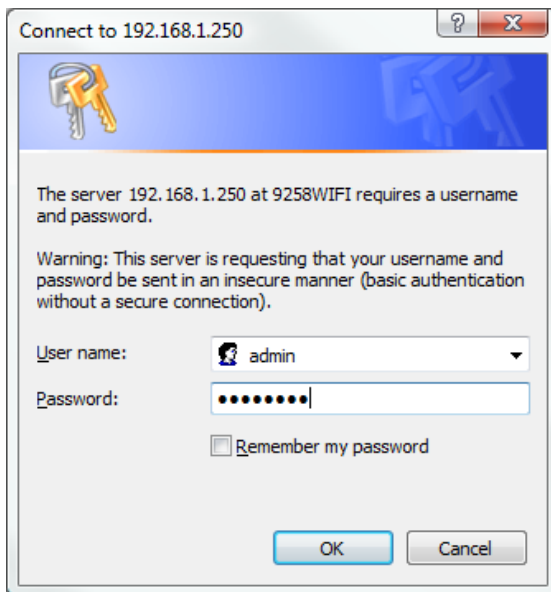

The default Username and Password for the 9828-P

Username : admin

Password : 12345678

The Control Console

The Right side Menu of the Web Interface for controlling the functionality and setup of the IP Power 9828-P.



The IP Power 9828-P Console consists of six main sections which will be explained in details below.

- **Top Column** : Date, Current Amp Usage & Device name, Column Display (for smart phone application)
- **IO Control** : Control , Schedule & Ping, M2M mode
- **Network** : Setting
- **Application** : Email , DDNS, Communication & IP Service
- **System** : Management, Information, SysLog & Firmware
- **Logout**

4.2 Top Column

4.2.1 Device name

This section show the device name. You can change the device name here: Application → IP Service → Device name Change name “ IP POWER 9828-P “ as “Enjoy 9828-P “

The screenshot displays the AVIOSYS web interface for the device IP POWER 9828-P. The interface is divided into several sections. On the left, there is a sidebar menu with categories like IO Control, Network, and Application. The 'Application' menu is expanded, and 'IP Service' is highlighted with a red box. The main content area shows the 'IP Service Setting (Search)' section, which is also highlighted with a red box. This section contains a table with the following fields: Enable (checked), IP Service Server (Server1), Device Name (IP_POWER), Country, City, and myipedit login Account. Below this table is a link 'Find IP_POWER device on myipedit.com' and an 'Apply' button. The 'CNT(MQTT) Setting (Remote control)' section is also highlighted with a red box, showing MQTT Service (IPPower), Enable (checked), Status (Connected), and an 'Apply' button.

Notice : Please do not use symbol like !@#%&*()_+ as the character of the device name .

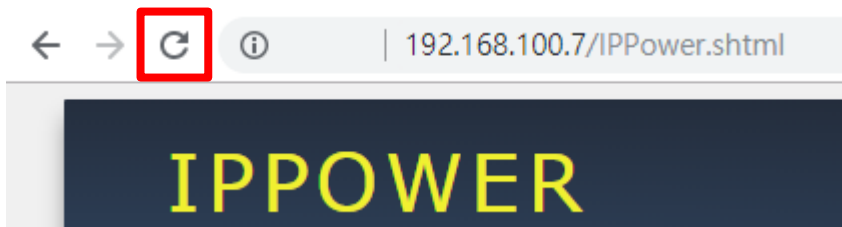

After apply the change, please click “ Refresh “ of the webpage to get the display update .

4.2.2 Column Display

For Smartphone user to control 9828-P easily, user can select to show or to hide the left control section by pressing the blue area near device name for Smartphone control :

- With left control section :
-



Without left control section :



4.2.3 Date and Time

In this section, it shows Time at **Year – Month – Date, Hours : Minutes : Seconds** .

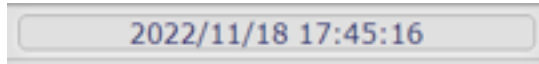

To setup the Time , Please go to “ System → Management → NTP Settings “ , please press “Apply” to save the new setting .

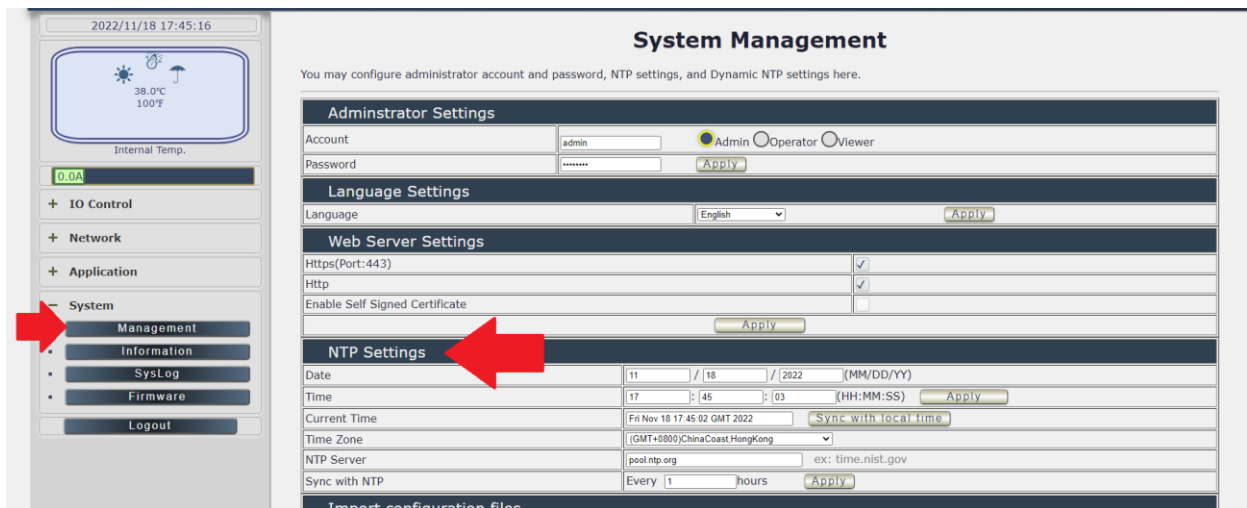

1. Time - Manual setting : fill the assigned time and then click “Apply “ in time section
2. Current time - sync with the local PC log into 9828-P .
3. NTP Server - sync with the assigned sever and can setup the times for sync

Notice: As using NTP server, as webpage time count will be slower than the device time, please refresh the webpage or use the telnet command “ to confirm the device time.

```
IP_POWER login: admin
Password:

BusyBox v1.12.1 (2019-07-08 01:01:56 PDT) built-in shell (ash)
Enter 'ioctrl -h' for a list of built-in commands.

# date
Mon Oct 7 13:54:37 GMT 2019
#
```

4.2.4 Current Usage & Temperature

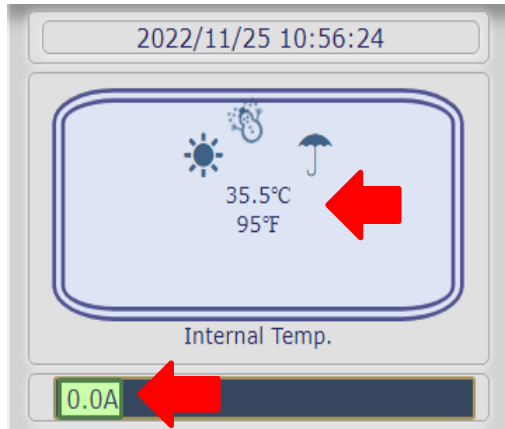

- Current : It show the total current usage of outlet 1 & 2. The maximum current is at 10A.
- Temperature: the sensor is in 9828-P box. Range -10 ~ 60 °C or 14 ~104(°F)

4.3 Power Control

The IO Control Section allows you to directly / automatically control the outlets of the 9828-P as well as schedule Daily, Weekly, and Monthly power cycles.

There are 4 sections: Control, Schedule, Ping, M2M mode

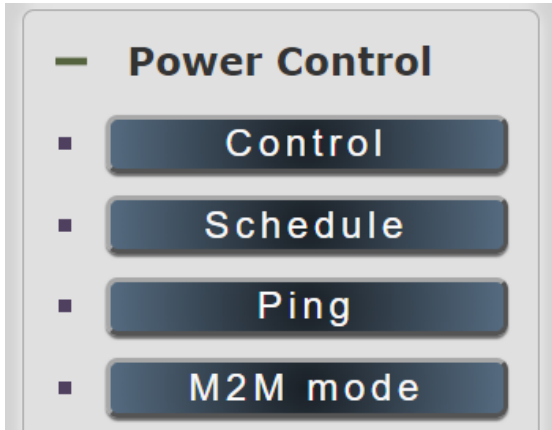

4.3.1 Control

There are 2 setting pages in this Section. One is “ Power Control “ and another one is “Advance Setup“

A. Power Control :

User can do the following 3 basic operation in this page :

1. Manual control: each port ON or OFF directly by pressing the power sign.
2. Power Cycle control : Manually Control the relay delay to turn ON / OFF .
The relay cycle time can be set from 1 to 9999 seconds

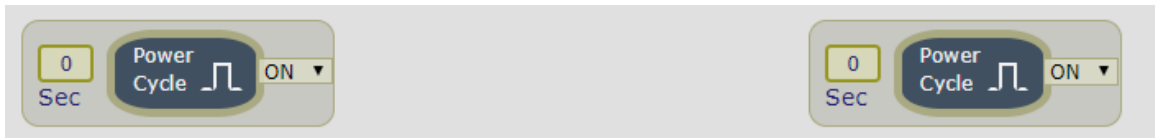

User can set up the time and the final status in power cycle as ON / OFF

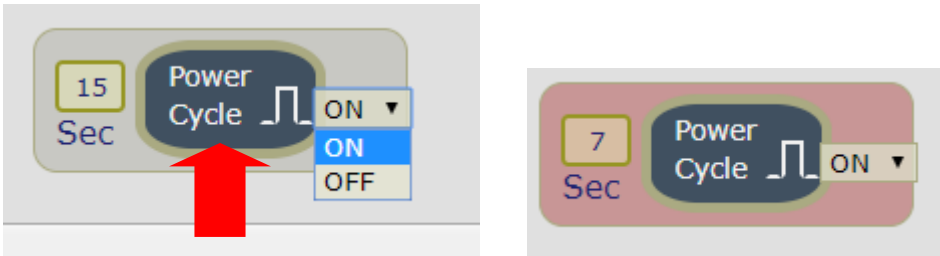

For example : (sec = seconds)

- Original Outlet as " OFF " , select final status as " ON " & fill 15sec :
After press power cycle button, the outlet will turn OFF for 15 seconds and then turn ON .

OFF (15 sec) → ON

- Original Outlet as " ON " , select final status as " ON " & fill 10sec :
After press power cycle button, the outlet will turn OFF for 10 seconds and then turn ON .

ON --> OFF (10 sec) → ON

- Original Outlet as " OFF " , select final status as " OFF " & fill 8 sec :After
press power cycle button, the outlet will turn ON for 8 seconds and then
turn OFF .

OFF → ON (8 sec) → OFF

- Original Outlet as " ON " , select final status as " OFF " & fill 5 sec :

After press power cycle button, the outlet will be ON for 5 seconds and then turn OFF .

ON (5 sec) → OFF

- 3 Group Setting : User can control more than one outlet by press the right side “Apply” button . For safety concern , each port of 9828-P will turn ON or OFF one after one .

For example : The below picture means that Power #1 is ON , Power #2 is OFF



The following 3 pictures shows that after press the power cycle with 5 seconds setting , the outlet “ Power1 “ will turn off for 5 seconds , then turn ON later . The power cycle action will execute after press the “ Power Cycle “ button .

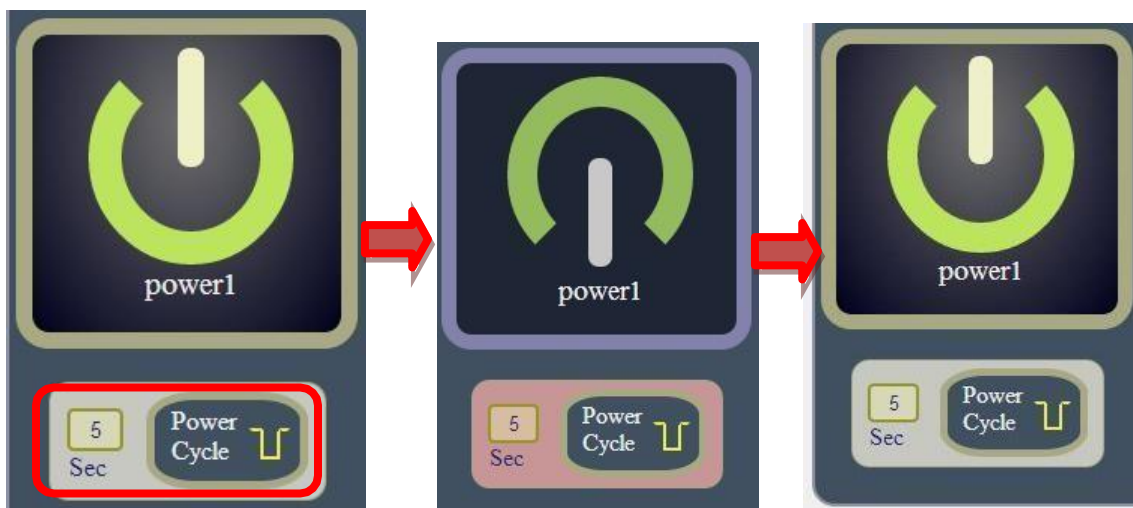

B. Advance Setup :

User can do the following 8 advance operation in this page :

- **Port Name setting:**

User can name each power by click the name above the power button

The number of character is max. 12 characters and Please change the name in English only and do not use symbol like !@#\$%^&*()_+

192.168.100.158 顯示
Please enter Power1 name:
power1
確定 取消

Port Name	Outlet1	Outlet2
	power1	power2

- **Notification Setting:**

Notification Setting		
Name	power1	power2
Forbidden off manually	<input type="checkbox"/>	<input type="checkbox"/>
Forbidden Power cycle	<input type="checkbox"/>	<input type="checkbox"/>
Email Alerts	<input type="checkbox"/>	<input type="checkbox"/>
Beep Alert	<input type="checkbox"/>	<input type="checkbox"/>
Power Cycle Time	60 Seconds	60 Seconds
Default Power Status	LAST	LAST

Apply

- Forbidden off manually :
Stop to control ON/OFF in the webpage manually .

9828-P will follow control by HTTP/CGI command or by Schedule setting.

- Forbidden Power cycle :
Stop to “power cycle” control in the webpage manually . 9828-P will follow control by HTTP/CGI command or by Schedule setting.

For example:

Forbidden outlet #1 & power cycle # 2 . The manual control button will be grey and can not control as following :

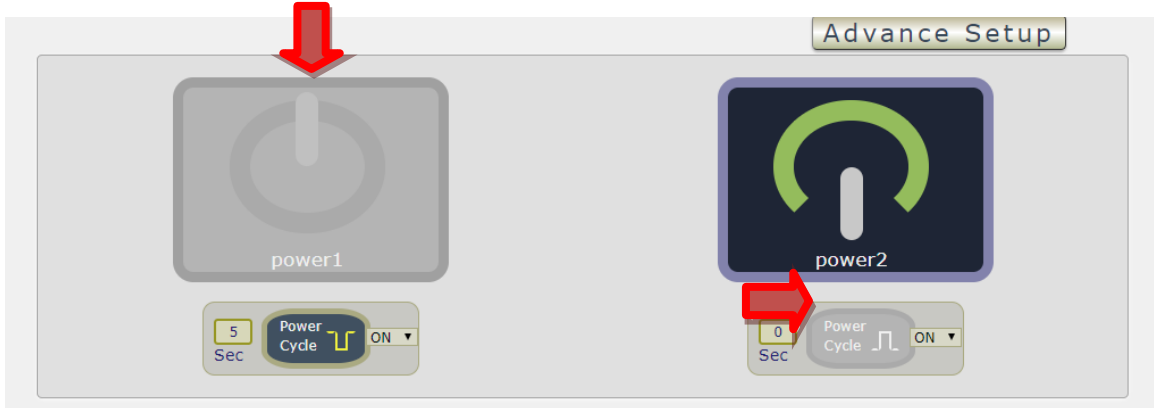

- E-mail Alarm Setting :

User can enable /disable the e-mail alarm here. Please refer the page 33 to setup the email information in "Application " → Email .

The e-mail alarm section allows 9828-P to notify user by following situation :

- Receive E-mail with IP information & MAC Address as 9828-P device boot up.
- Receive E-mail as ON/OFF status change in each output .

- Beep Alert : User can setup the operation beep (short time beep) sound here.

- Default Power Status: The control section allow user to set the power status on ON or OFF or LAST when the device power Rebooted . The output will be same status as choose LAST before the device power turn off. To save the setting here , please click "Apply " button .

Note : Please change the name in English only and do not use symbol like !@#%&^&*()_+

● **Emergency safety switch setting:** it is for the two buttons at the front panel

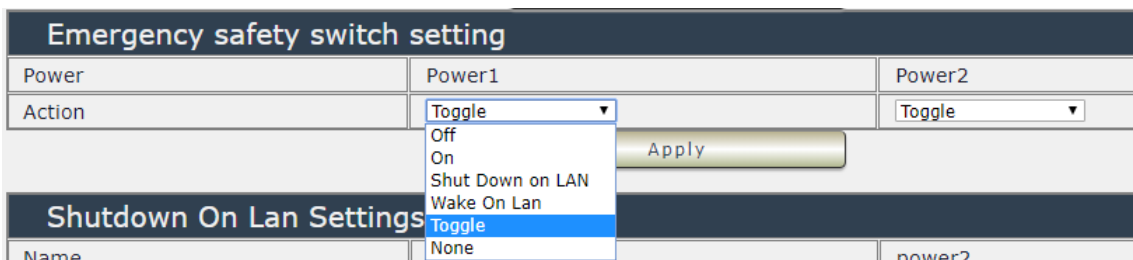

User can select different function of the individual button as OFF, ON, Shutdown on Lan, Wake On Lan , Toggle and None(Disable) .

- **Default Power Delay:** When you enable the function, you can setting the delay time to turn on the power.

Default Power Delay		
Enable	Power1	Power2
<input type="checkbox"/>	11 Seconds	12 Seconds
Apply		

- **Power Interval:** It's the delay function which works on the ON/Off buttons for the manual control at the interface of the webpage. User can delay the action time as press the control button in webpage.

Power interval	
Enable	Interval time(1~5sec)
<input type="checkbox"/>	3 Sec
Apply	

- **WOL&SOL:** Trigger Relay: When you enable the WOL function, turn the Trigger Relay on will connect the WOL and SOL function.

WOL & SOL trigger Relay	
OFF	Apply

- **Shutdown on LAN & Wake On Lan setting:**

Shutdown On Lan Settings	
Name	Delay Time
power1	60 Seconds
power2	60 Seconds
Apply	

Wake On Lan Settings	
Control Outlet	MAC
power1	000000000000 <input type="button" value="Send"/>
power2	000000000000 <input type="button" value="Send"/>

- Shutdown on LAN

9828-P can be used to safely turn off the **WINDOWS or LINUX** system through Network. With this feature you can remotely shutdown any system which that is connected to the IP Power 9828-P through normal Windows / LINUX shut down procedure. Before operating the software shutdownfunction it is essential to install our software.

Please check the software in the SDK section of online CD site.

File name : Shutdown_On_LAN

NOTE : The delay time setup in this section is for “ Shutdown ON LAN “ procedure .
Not for outlet ON/OFF function

- Wake up on LAN (= WOL)

This is a application for PC / Server / Main board which had been enable the “ WAKE ON LAN “ function in own setting . User need to know the MAC address of the PC /Server to be wake up.

WOL in Schedule Setting :

Schedule List

1 Duration Mode Once Every Week Every Day

Date
Time : : (Hr:Min:Sec)

Schedule power action

power1

- OFF
- ON
- OFF
- CYCLE
- WOL
- SOL**
- Reboot

power2

OFF

Apply No.1 Sch Delete

WOL in PING Setting :

Ping List

Global Ping Base Setting

Ping Interval	<input type="text" value="5"/> Sec.	Response Time Out	<input type="text" value="900"/> ms.
Ping After Action Delay	<input type="text" value="5"/> Sec.	Action Max repeat times	<input type="text" value="1"/> (0=non stop)

Conditional Mode Single OR And

IP & Host Name	Failed times then action	Repeat	Rule No1
<input type="text" value="www.yahoo.com"/> <input type="button" value="Check"/>	<input type="text" value="00"/>	Stop	
<input type="text" value="www.google.com"/> <input type="button" value="Check"/>	<input type="text" value="00"/>		
<input type="text" value="www.yahoo.com"/> <input type="button" value="Check"/>	<input type="text" value="00"/>		
<input type="text" value="www.google.com"/> <input type="button" value="Check"/>	<input type="text" value="00"/>		

Ping failure action

power1

- OFF
- ON
- OFF
- CYCLE
- WOL
- SOL**
- Relink

power2

OFF

Apply Rule Delete

4.3.2 Schedule

In this section , user can see the setting schedule list first up to 29 rules . To setup each schedule , please press “ Schedule Setting “ , then user can get the “ Schedule List “ page as following :

Please click the button to switch between “ Schedule Setting “ & “ Schedule list “ :

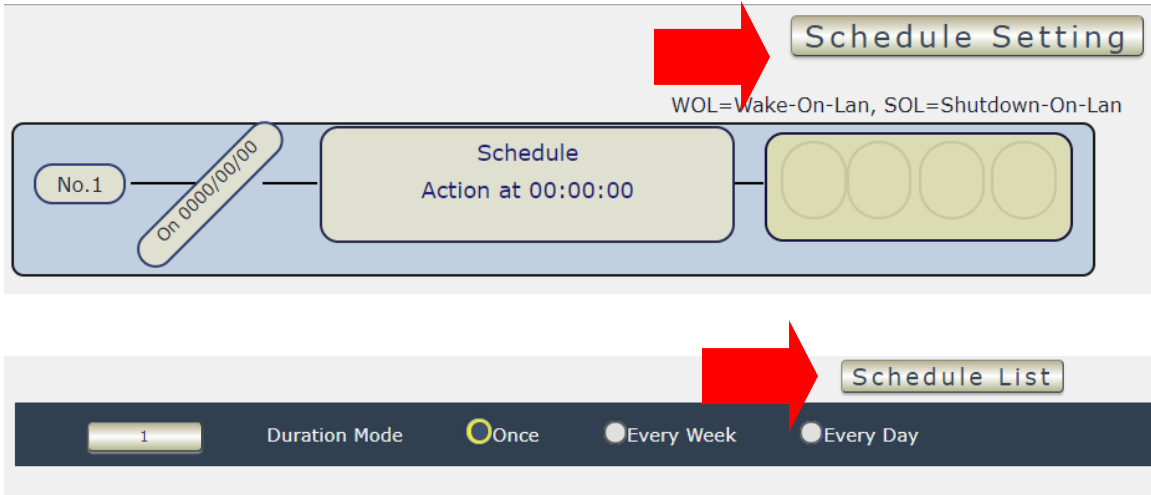

The schedule allows you to control the power outlet turn ON , OFF , Cycle , WOL , SOL or Reboot at the assigned time user arrange in schedule

- Adding a Scheduled Event

1. Select the Action Duration :

There are 3 setting - Once , Every Day . Every Week

2. Select a Specific Date Range where the device will repeat the desired actions during the time specified.

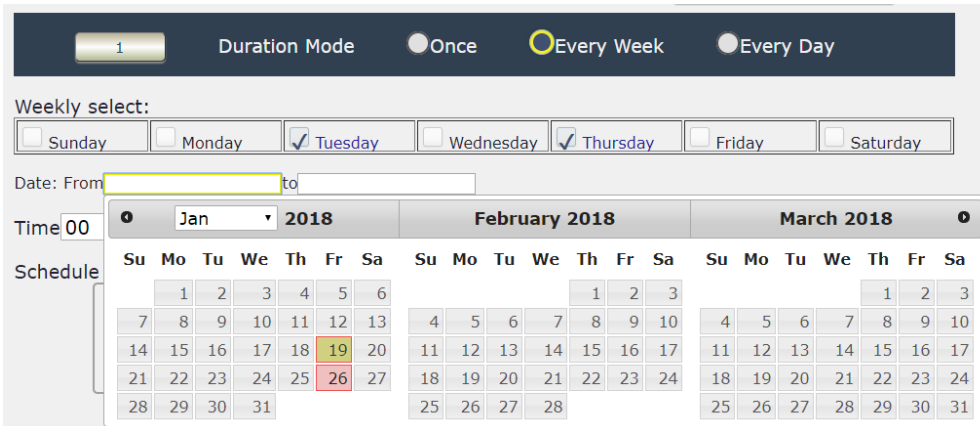

3. Select the Time Period.

- Choose the Action : Enable power # by clicking in the small square to mark “ v “ , and select one from the power action of OFF/ON/RESET as you need. .

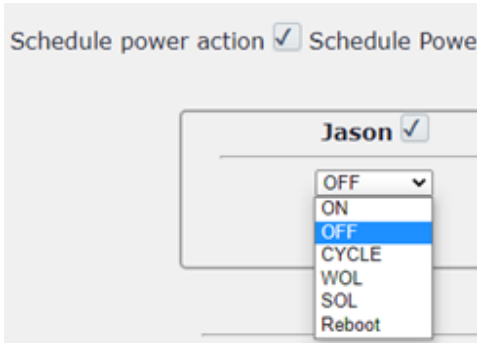

Once the scheduler has been Set Up , hit the “ ADD No.:X Power Schedule “ button and you will see your setting located on the bottom of the Action section .

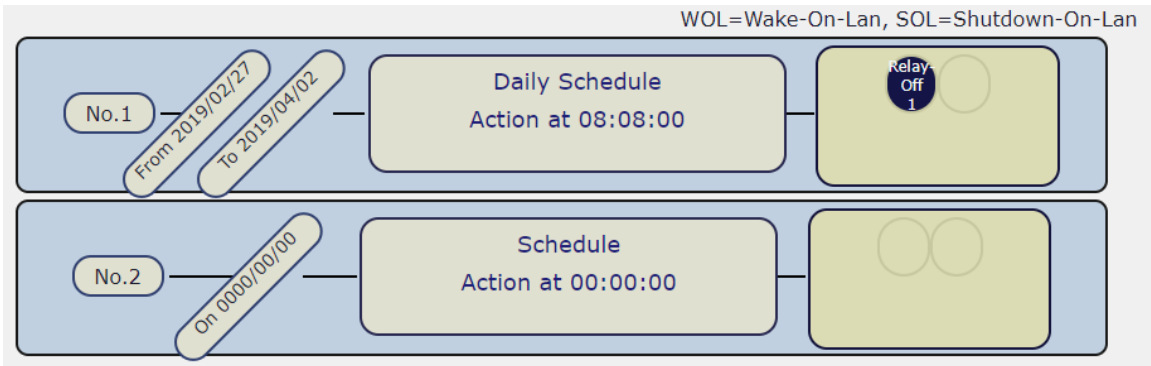

- **Apply / Edit a Schedule Event :**

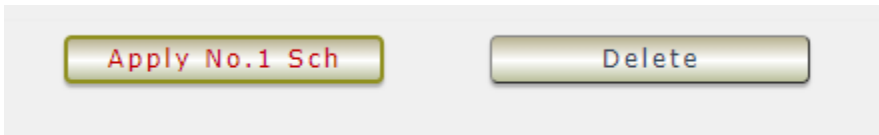

Please select the Rule you want to edit in Scheduler Table. , Change the setting like Duration , Date , Time and Action. Then Press “Apply Np. X Sch “ button to confirm the setting and you will see the page refresh and new setting display in Scheduler list

- **Delete - Click “ Delete “ button to remove a rule from the list .**

4.3.3 Ping

The Ping function allows the device to Ping an IP Address automatically to act as a watchdog to make sure the device getting Ping and working properly. Please Click the button to switch between “ Ping Setting “ & “ Ping List “ . User can hide the setting section by press “ Ping List “
“There are 4 rules for Ping .

- **Ping List Page :**

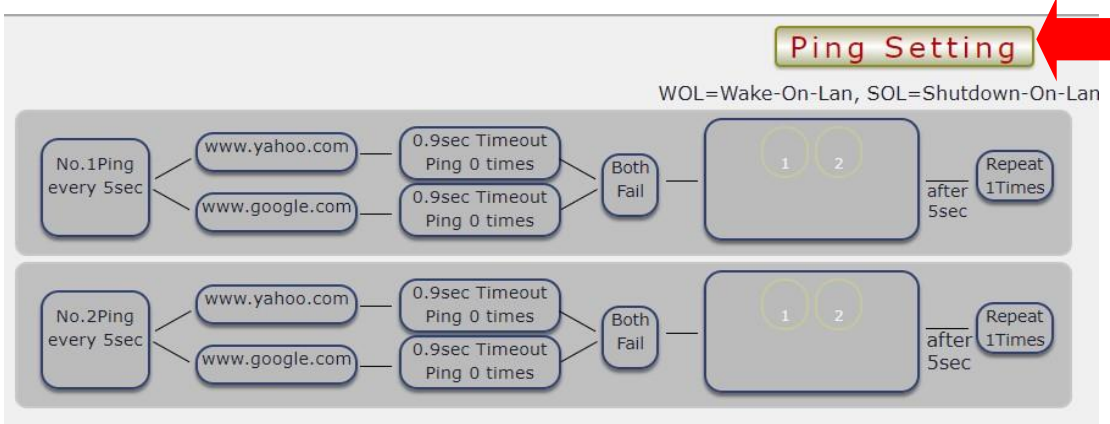

- **Ping Setting Page :**

Global Ping Base Setting

Ping Interval	5 Sec.	Response Time Out	900 ms.
Ping After Action Delay	5 Sec.	Action Max repeat times	1 (0=non stop)

Apply

Conditional Mode Single OR And

IP & Host Name	Failed times then action	Repeat
www.yahoo.com	00	Stop
www.google.com	00	
www.yahoo.com	00	
www.google.com	00	

Ping failure action

Apply Rule Delete

WOL= Wake On Lan, SOL= Shutdown On Lan

The screenshot shows the 'Ping List' button highlighted with a red arrow. The 'Global Ping Base Setting' section includes input fields for Ping Interval (5 Sec), Response Time Out (900 ms), Ping After Action Delay (5 Sec), and Action Max repeat times (1). Below this is a table for 'Conditional Mode' with 'And' selected. The table has columns for 'IP & Host Name', 'Failed times then action', and 'Repeat'. The first two rows show www.yahoo.com and www.google.com with failed times set to 00 and repeat set to Stop. There are 'Check' buttons for each row. At the bottom, there are 'Apply Rule' and 'Delete' buttons.

There are 3 sections of the setting area :

1. Setting Rule Numbers :

User can click to select different rules numbers at the right side button " Rule No: X " as following pictures . There are 4 rules available.

The screenshot shows the 'Ping List' configuration interface. It is divided into two main sections: 'Global Ping Base Setting' and 'Conditional Mode'.

Global Ping Base Setting:

Ping Interval	5 Sec.	Response Time Out	900 ms.
Ping After Action Delay	5 Sec.	Action Max repeat times	1 (0=non stop)

Apply

Conditional Mode: Single OR **And** (selected)

IP & Host Name	Failed times then action	Repeat	Rule No
www.yahoo.com	00	Stop	Rule No1
www.google.com	00		
www.yahoo.com	00		
www.google.com	00		

Ping failure action

Apply Rule Delete

A red arrow points to the 'Rule No1' button in the rightmost column of the Conditional Mode table.

2. Ping Base Setting :

The screenshot shows the 'Ping List' configuration interface, focusing on the 'Global Ping Base Setting' section.

Ping Interval	5 Sec.	Response Time Out	900 ms.
Ping After Action Delay	5 Sec.	Action Max repeat times	1 (0=non stop)

Apply

A red arrow points to the 'Apply' button at the bottom of the Global Ping Base Setting section.

- Ping Interval : The number of seconds (Sec., 1~9999) between each ping .
- Response Time Out : The number of milliseconds (ms. , 1~9999) of the device will wait for a response from the Pinged device if no ping is detected within this time it will be considered a Ping failure.
- Ping After Action Delay : After ping finished , do the action after setting seconds (Sec.)
- Action Max. repeat times: Setup the times of Action after Ping Failure .
Set 0 means action non stop - Keep action & no limit times.

As setting finished, please click " Apply " to save the setting in this area , the webpage will refresh and user can see the final setting result. Ten different set up rules for different port .

Other Setting :

The setting here is for each rule.

Conditional Mode		Single	OR	And
IP & Host Name		Failed times then action		Repeat
www.yahoo.com	Check	00		Stop
www.google.com	Check	00		
www.yahoo.com	Check	00		
www.google.com	Check	00		

Ping failure action

Apply Rule Delete

- Conditional Mode :

User can select the action activate by one / two IP Host failure or either one fail

- Single : Execute Action by one IP Host failure .
- OR : Execute Action by either one IP Host failure as setting 4 pcs IP Host
- And : Execute Action by both IP Host failure as setting 4 pcs IP Host

Single : 9828-P will Ping one IP address. As the IP fail times reach to the setting times .
Action (ON/OFF/RESET) will be activated .

OR : 9828-P will Ping 4 IP address. Either one IP fail times reach to the setting times.
Action (ON/OFF/RESET) will be activated.

AND : 9828-P will Ping 4 IP address. Both IP fail reach to the setting times.
Action (ON/OFF/RESET) will be activated.

- IP & Host Name : Input the IP Address (ex: 122.116.123.138) or Host - web address (ex: www.google.com) user would like to Ping.
User can use the “ ping test “ bottom to check the address valid or not
- Failed times then action : Setup the times as get ping failure for 9828-P to execute the setupON/OFF / Reset action of setting . ping onetime and (range 00~99)
- Repeat : After the ON/OFF/Reset action , user can setup the Ping action to keep ping (Continue) or to Stop Ping (Stop) .
- Enable Ping function : In the selected Rules number , please select the outlet number power to activate as ping fails and then press “ Apply Rule “ button to confirm the setting .

Ping List

Global Ping Base Setting			
Ping Interval	5 Sec.	Response Time Out	900 ms.
Ping After Action Delay	5 Sec.	Action Max repeat times	1 (0=non stop)
Apply			
Conditional Mode			
<input type="radio"/> Single <input type="radio"/> OR <input checked="" type="radio"/> And			
IP & Host Name	Failed times then action	Repeat	
www.yahoo.com <input type="button" value="Check"/>	00	Stop	Rule No1
www.google.com <input type="button" value="Check"/>	00		
www.yahoo.com <input type="button" value="Check"/>	00		
www.google.com <input type="button" value="Check"/>	00		
Ping failure action <input checked="" type="checkbox"/>			
power1 <input checked="" type="checkbox"/> <div style="border: 1px solid black; padding: 2px; display: inline-block;"> OFF ON OFF CYCLE WOL SOL Relink </div>		power2 <input type="checkbox"/>	
Apply Rule		Delete	

- Ping failure action :

When the number of Ping Failures times have been reached. The device can be set to " ON , OFF or Reset " function

Reset: Can set up the time gap from OFF to ON. The " Sec " section is for action as Reset only.

- ON
 - OFF
 - Cycle: It means outlets turn OFF to ON
 - WOL: Wake On Lan
 - SOL: Shutdown On Lan
 - Relink: It means to reconnect the network. If the setting is DHCP, 9828-P may get a new IP address as reconnect to the router.
- > P.S: If the network connection is not stable or change it's IP on internet frequently, we suggest to enable this function to Ping the 4G router. 9828-P will relink the network as there is no ping reply from the network.

The setting times range is 1 to 999 sec.

Select the number of Ping Failures that user prefer to do before the action is activated.

EX: Result of setting

4.3.4 M2M mode

- This is a function to control another 9828-P automatically . There are two directions : Control in LAN or Control through Internet – MQTT

1. M2M- Local (LAN):

In this function , device B is a SLAVE device . User need to select enable , filled the IP address and login information of the HOST / Master device.

M2M(LAN) Setting	
Enable	<input type="checkbox"/>
Host	<input type="text"/>
Port	80
User	admin
Password

Apply

- For example :

One 9828-P name device A (IP : 10.33.122.50) , another 9828-P name device B (10.33.122.28) .

- In the webpage of device B , we enable the function , set up the IP and the login username and password of device A (as HOST).
 - As we setup the outlet # 1 of device A as ON , then the outlet #1 of device B will turn ON.
 - As we setup the outlet # 2 of device A as OFF , then the outlet #2 of device B will turn OFF too.
- Before you setting M2M. please open two device webpage and enable the setting at the same time, if you only setting device A to enable M2M, device B won't follow device A action until both device have set M2M enable.

Notice : User can set device A to control B and also device B to control A , then the two devices will be auto control of each other.

2. M2M-MQTT (Internet) :

- To use this function , user need to enable the CNT(MQTT) function (register to Aviosys MQTT HOST). In this function , device B is a MASTER device . User need to select enable, filled the MAC address and login information of the SLAVE device .

The screenshot shows the 'M2M(LAN) Setting' interface. At the top right, there is a yellow button labeled 'MQTT' with a red arrow pointing to it from the left. Below this is a table with the following fields:

Enable	<input type="checkbox"/>
Host	<input type="text"/>
Port	80
User	admin
Password	*****

At the bottom center of the form is a yellow 'Apply' button.



M2M machine outputs are corresponding to another machine outputs

Local

M2M(Internet) Setting

MQTT M2M Enable

Controlled Device Setting

MAC	User	Password	
<input type="text" value="007623000310"/>	<input type="text" value="admin"/>	<input type="text" value="*****"/>	<input type="button" value="Test"/>

- Before setting the MQTT, click the the IP service in Application, and you will see the “ CNT(MQTT) Setting (Remote control) “, follow the red button to click the enable function, then choose the IPPower option in MQTT Service. After the setting, click the apply and the MQTT function will be enable.

Notice: All the IP device want to connect each other through MQTT must get this procedure.

The screenshot shows two parts of the configuration interface. On the left is a sidebar menu with categories: Power Control, Network, and Application. Under Application, 'IP Service' is highlighted with a red box. On the right, the 'IP Service Setting (Search)' form is visible, with fields for Enable, IP Service Server, Device Name, Country, City, and myipedit login Account. Below this is a link 'Find IPPOWER 9858 device on myipedit.com' and an 'Apply' button. The second form, 'CNT(MQTT) Setting (Remote control)', has a dropdown menu for 'MQTT Service' with 'IPPower' selected, and an 'Enable' checkbox which is checked. A red arrow points to the 'IPPower' dropdown. An 'Apply' button is at the bottom.

- Setting the MQTT:

M2M machine outputs are corresponding to another machine outputs

Local

M2M(Internet) Setting

MQTT M2M Enable

Controlled Device Setting

MAC	User	Password	
<input type="text" value="007623000310"/>	<input type="text" value="admin"/>	<input type="password" value="....."/>	<input type="button" value="Test"/>

- Click the button in MQTT M2M Enable.
- In Controlled Device Setting, type the Device MAC you want to connect with. We recommend not to change the user and password in the first, then click apply, the other device connect the device you are setting.
- For example : one 9828-P name device A (MAC : 007623000310) , another 9828-P name device B (MAC : 007650002DF8, IP - 10.33.122.28)
 - In the webpage of device B , we enable the function , set up the IP and the login username and password of device A (as SLAVE) .
 - As we setup the outlet # 1 of device B as ON , then the outlet #1 of device A will turn ON too
 - As we setup the outlet # 2 of device B as OFF , then the outlet #2 of device A will turn OFF too

Notice : 1. User can set device A to control B and also device B to control A , then the two devices will be auto control of each other .

4.4 Network

There are 3 sections in this port : LAN Network, DNS setting and Port setting

LAN Network Settings

The network status is connected by ether cable with RJ45 connector. There are 3 ways to connect the network : By Static IP / DHCP / UPNP

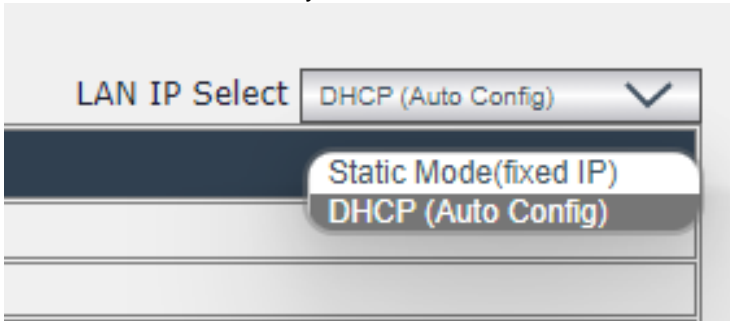

A. Static Mode (fixed IP)

Setup IP address , DNS and Port manually. This allows the 9828-P to obtain an IP Address automatically from user's server connected to Internet. Recommended for users who need to control through Internet.

Please do fill up the correct gateway / port for login from Internet .

Please do fill up the correct DNS server for sending / receiving email (alarm) .

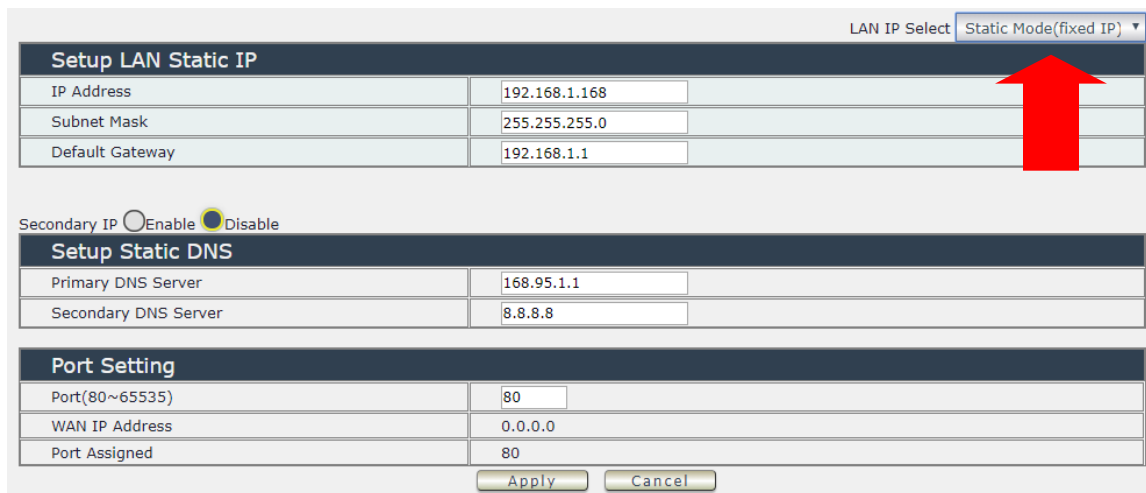
A screenshot of the LAN Network Settings configuration page. At the top right, there is a dropdown menu for 'LAN IP Select' set to 'Static Mode(fixed IP)'. Below this is a section titled 'Setup LAN Static IP' with a table for IP configuration. A red arrow points to the 'LAN IP Select' dropdown. Below that is a section for 'Secondary IP' with 'Enable' and 'Disable' radio buttons. The 'Disable' button is selected. Below that is a section titled 'Setup Static DNS' with a table for DNS server configuration. At the bottom is a section titled 'Port Setting' with a table for port configuration. At the very bottom are 'Apply' and 'Cancel' buttons.

Setup LAN Static IP	
IP Address	192.168.1.168
Subnet Mask	255.255.255.0
Default Gateway	192.168.1.1

Secondary IP Enable Disable

Setup Static DNS	
Primary DNS Server	168.95.1.1
Secondary DNS Server	8.8.8.8

Port Setting	
Port(80~65535)	80
WAN IP Address	0.0.0.0
Port Assigned	80

Apply Cancel

Secondary IP:

This function like a “ backdoor ”. If the user forget the IP address, they can log in through this IP as it enable.

Secondary IP Enable Disable

Get DNS from DHCP Server

Primary DNS Server	168.95.1.1
Secondary DNS Server	8.8.8.8

Port Setting

Port(80~65535)	80
WAN IP Address	0.0.0.0
Port Assigned	80

Apply

B. DHCP Mode

Obtain IP address via DHCP mode. setup the DNS and port

This allows the 9828-P to obtain an IP Address automatically from user`s server connected to Internet. Recommended for non- advance users.
User can only revise the Host Name under DHCP mode. This is also the default setting for fast LAN connection solution.

As the IP from DHCP Service of user`s router will be changed by router . 9828-P will rememberlast IP of 9828-P assigned by user`s router in “Last DHCP state “ for information

Please do fill up the correct gateway / port for login from Internet .
Please do fill up the correct DNS server for sending / receiving email (alarm) .

LAN IP Select DHCP (Auto Config)

Get LAN IP from DHCP

IP Address	192.168.100.137
Subnet Mask	255.255.255.0
Default Gateway	192.168.100.1

Secondary IP Enable Disable

Get DNS from DHCP Server

Primary DNS Server	127.0.0.1
Secondary DNS Server	168.95.1.1

Port Setting

Port(80~65535)	80
WAN IP Address	0.0.0.0
Port Assigned	80

Apply Cancel

C. PPTP Mode

Enable your PPTP first, and setting your IP address, User name password, then click the apply to activate the PPTP mode

PPTP Mode	
PPTP	<input type="radio"/> Enable <input checked="" type="radio"/> Disable
Pptp Server IP Address	pptp_server
User Name	pptp_user
Password
VPN IP Address	0.0.0.0

Apply

D.UPNP Mode

With UPNP function, user can log in webpage through Internet without setting Port forwarding / port mapping in your router. No matter use "FIX IP" or "DHCP", user can enable this UPNP function.

Notice : It support to pass through one router and may not work as 9828-P under multiple routers.

Port Setting	
Port(80~65535)	80
WAN IP Address	0.0.0.0
Port Assigned	80

Apply Cancel

UPNP	
Enable	<input type="checkbox"/>
Port	44615 (81~65535)

Apply

Please do fill up the correct gateway / port for login from Internet.

Please do fill up the correct DNS server for sending / receiving email (alarm).

4.5 Application Settings

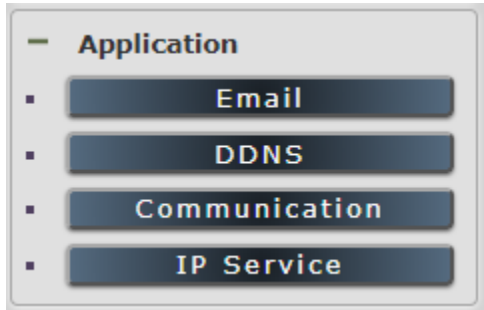

4.5.1 Email

There are 2 sections in this part -- E-mail setting and POP3 Control :

E-mail Setting

SMTP Server :	Gmail <input type="text" value="smtp.gmail.com"/>
Port :	587 <input checked="" type="checkbox"/> StartTLS
User :	aviosys102@gmail.com
Password :	*****
From :	aviosys100@gmail.com
To :	aviosys101@gmail.com
To1:	aviosys103@gmail.com
To2:	aviosys104@gmail.com
<input type="button" value="Email Test"/> <input type="button" value="Apply"/>	

- **Email Setting :**

User can get e-mail advice as one of the following situation happen :

- Receive E-mail with IP information & MAC Address as 9828-P device boot up.
- Receive E-mail as ON/OFF status change in each output .

Notice : To send out the e-mail successfully , please double check the setting of user DNS . (Network → DNS setting)

The 9828-P allows user to send from public e-mail account , such as @gmail or @hotmail or @yahoo.com

- **SMTP Server:** This is the mail server of sender

If user select @gmail or @hotmail account as SMTP Server , 9828-P will fill the SSL & Port automatically

- **Port** : This is the port of SMTP Server. Most common port to send out e-mail is port 25
- **Start TLS** : It depends on the inquire of the email server to enable or disable this inquire .As use Gmail account, please enable this function.
- **User** : Login for the e-mail address. Ex: 9828-P@gmail.com
- **Password**: Password for the e-mail address. EX : 12345678
- **From** : Mail sender address to send the E-Mail out. Ex.: 9828-P@gmail.com
- **To**: Mail receiver address to get the E-Mail in. Ex.: 9223@hotmail.com
- E-mail test : Can help to check if the e-mail setting works.
- Apply : To store the setting in this section.

For example :

1. Get Email alarm as outlet changed :

2022/11/25 10:56:24

Power Control

Internal Temp. 35.5°C 95°F

0.0A

IO Control

- Control
- Schedule
- Ping
- M2M mode

Port Name Setting

Outlet1	Outlet2
power1	power2

Notification Setting

Name	power1	power2
Forbidden off manually	<input type="checkbox"/>	<input type="checkbox"/>
Forbidden Power cycle	<input type="checkbox"/>	<input type="checkbox"/>
Email Alerts	<input type="checkbox"/>	<input type="checkbox"/>
Beep Alert	<input type="checkbox"/>	<input type="checkbox"/>
Power Cycle Time	30 Seconds	30 Seconds
Default Power Status	ON	ON

Apply

● POP3 Control

User can control each port turn ON or turn OFF by e-mail. The command format is limited .

Please enable the function first .

POP3 Control	
POP3 Server :	Gmail pop.gmail.com
From :	aviosys@gmail.com
Port :	110
User :	aviosys1
Password :	*****
Tag :	Test
Interval(Minute) :	2
Mail Number :	100
CTRL Format :	<input checked="" type="radio"/> Subject <input type="radio"/> Body

Apply

Example:
E-Mail Test:
yourmail
Subject:
IPPOWERCTRL:TAG=Test;POWER1=OFF;POWER2=OFF;POWER3=OFF;POWER4=OFF
Body:

Submit

Settings Section :

To set up 9828-P be controlled by e-mail , user need to know the both **sender`s e-mail address and receiver`s e-mail account Name and Password.**

- **POP3 Server:** This is receiver's mail server
- **From :** Sender's email address .Ex.: aviosys@gmail.com
- **Port :** This is the port of POP3 Server.

If user select @gmail or @hotmail account as SMTP Server , 9828-P will fill the SSL & Port automatically.

- **User :** Username to login the receiver's e-mail Ex.: aviosys1 or aviosys1@gmail.com
- **Password:** Password for the e-mail address. EX. : 12345678
- **Tag :** User can use any message for 9828-P to recognize this mail as 9828-P command mail .

EX.:

As type " Test " in TAG area, the command contents is as following:

IPPOWERCTRL:TAG=Test;POWER1=OFF;POWER2=OFF;POWER3=OFF;POWER4=OFF

- **Interval (minutes) :** The period of time between Send and Receive the command e-mail.

- **Mail Number** : For 9828-P to search as command mail in the number of your email receiver latest . EX.: setup 20 that 9828-P will check the latest 20 pcs email in receivers mail box forthe 9828-P command mail

- **CTRL format** : Control format by subject or by body (e-mail contents)

For example : Use Gmail as sender and receiver

- Sender`s e-mail : 123@gmail.com
- Username to log in sender`s @gmail : 123@gmail.com or abc@def.com
- Password to log in sender`s @gmail : 12345678

Command format & Example :

User can get the e-mail command contents in the section . And execute an e-mail as press "Submit " if user has e-mail setting in the PC as following :

CTRL Format : Subject Body

Apply

Example:
E-Mail Test:

Subject:
 IPPOWERCTRL:TAG=Test;POWER1=OFF;POWER2=OFF;POWER3=OFF;POWER4=OFF
Body:

Submit

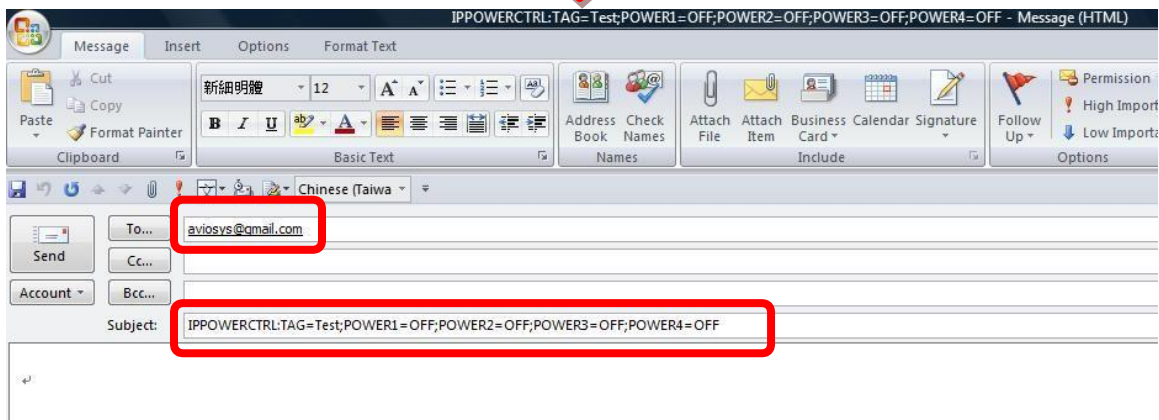

Command format :

IPPOWERCTRL:TAG=Test;POWER1=OFF;POWER2=OFF;POWER3=OFF;POWER4=OFF

There are 2 section of the command

1. **IPPOWERCTRL:TAG=Test**

This is command part. Beside the tag message part (like Test on above example) user can change in setting section , the other command must be **CAPITAL** and are fixed content .

2. **;POWER1=OFF;POWER2=OFF;POWER3=OFF;POWER4=OFF**

This is to set the outlet number (POWER1=) and action (ON/OFF) , user can only control 1~2port ON/OFF by e-mail. Do each outlet command

EX.: Put " 14ON" in tag section and place the command as following : (at subject or body depends one user's setting) :

IPPOWERCTRL:TAG=14ON;POWER1=OFF;POWER4=ON

E-mail example :

- Execute e-mail command by " Subject "

The screenshot shows the 'CTRL Format' interface. At the top, there are two radio buttons: 'Subject' (selected) and 'Body'. Below them is an 'Apply' button. The main area contains an 'Example:' section with an 'E-Mail Test:' label and a text input field containing 'yourmail'. Below that, the 'Subject:' field contains the command: 'IPPOWERCTRL:TAG=Test;POWER1=OFF;POWER2=OFF;POWER3=OFF;POWER4=OFF'. The 'Body:' field is empty. A red box highlights the 'Subject' radio button and the 'Subject' field.

- Execute e-mail command by " Body "

The screenshot shows the 'CTRL Format' interface. At the top, there are two radio buttons: 'Subject' and 'Body' (selected). Below them is an 'Apply' button. The main area contains an 'Example:' section with an 'E-Mail Test:' label and a text input field containing 'yourmail'. Below that, the 'Subject:' field is empty. The 'Body:' field contains the command: 'IPPOWERCTRL:TAG=Test;POWER1=OFF;POWER2=OFF;POWER3=OFF;POWER4=OFF'. A red box highlights the 'Body' radio button and the 'Body' field. At the bottom, there is a 'Submit' button.

4.5.2 DDNS

The DDNS section allows user to setup the 9828-P with a DDNS server (i.e. www.dyndns.com). After the server has been setup correctly, enter the necessary information into the 9828-P DDNSsettings.

Note : The DNS server will have extra change as apply new account.

DDNS

DDNS Setting	
Enable	<input type="checkbox"/>
Service Provider :	None ▾
Account :	None Dyndns.org freedns.afraid.org www.zoneedit.com www.no-ip.com
Password :	
Domain Name :	

Account : the Username / account name of DDNS account

Password : the Password of DDNS account

Domain name : The DDNS name user apply . Ex.: abc.dyndns.org

4.5.3 Communication

9828-P supports SNMP, Telnet , Modbus TCP and BACnet TCP

Communication Setting:

SNMP:	
Enable	<input type="checkbox"/>
SNMP version:	1.2c
Community Authority :	N/A
Community Name :	private
Trap type :	N/A
Host(192.168.1.1:162) :	192.168.1.1:162
Trap Community :	private
MIB file	IPPOWER-MIB.txt
<input type="button" value="Apply"/>	

TELNET:	
Enable	<input checked="" type="checkbox"/>
SSH	<input checked="" type="checkbox"/>
SSH-KEY	<input type="button" value="Renew"/>
<input type="button" value="Apply"/>	

TCP Modbus	
Modbus Enable	<input type="checkbox"/>
Port	502
<input type="button" value="Apply"/>	

BACnet	
Enable	<input type="checkbox"/>
Port	47808
<input type="button" value="Apply"/>	

1. SNMP

This section is for development of system integrator who is familiar with SNMP knowledge. In community Authority , user can select “ Read only” or “Read / Write”

Communication Setting:

SNMP:	
Enable	<input type="checkbox"/>
SNMP version:	1.2c
Community Authority :	N/A
Community Name :	N/A
Trap type :	N/A
Host(192.168.1.1:162) :	192.168.1.1:162
Trap Community :	private
MIB file	IPPOWER-MIB.txt
<input type="button" value="Apply"/>	

In “ Trap “ type ,user can select “ v1 trap “ , “ v2c trap “ or “ v2c inform”

Communication Setting:

SNMP:	
Enable	<input type="checkbox"/>
SNMP version:	1.2c
Community Authority :	N/A
Community Name :	private
Trap type :	N/A
Host(192.168.1.1:162) :	N/A
Trap Community :	v1 trap
MIB file	IPPOWER-MIB.txt

In MIB file section , user can get MIB information.

2. Telnet

In This section is for development of system integrator who is familiar with Telnet to enable /disable

You can decide to enable/disable the SSH function

TELNET:	
Enable	<input checked="" type="checkbox"/>
SSH	<input checked="" type="checkbox"/>
SSH-KEY	<input type="button" value="Renew"/>

Please enable the telnet function in “ Application “ → “ Communication “



```

c:\ Telnet 192.168.1.18
#
# ioctrl -h
-----**
Usage: ioctrl
[-h] ! --help l.....: display this help
[-s] ! --setpower p6=0011 or p6x=1(x=1,2,3,4)l.....: turn on/off ports on the d
evice
[-p] ! --getpower l..: get the on/off status of the device
[-c] ! --current l.....: get the current value of the device
[-t] ! --temp l.....: get the temperature value of the device
[-v] ! --version l.....: display version information
-----**
# ioctrl -s p6=1111
p61 ok,p62 ok,p63 ok,p64 ok,
# ioctrl -c
Current value: 0.000000, 0.000000, 0.000000, 0.000000
# ioctrl -t
Temperature value: 32.299999
# ioctrl -v
IO CONTROL Version: 1.0
Compilation Date....: May 14 2013
Compilation Time....: 10:44:47
# ioctrl -p
Power Status: 1, 1, 1, 1
#
  
```

3. Modbus TCP

Modbus: We supply the TCP models of Modbus control

TCP Modbus	
Modbus Enable	<input type="checkbox"/>
Port	502
<input type="button" value="Apply"/>	

4. BACnet TCP

In this section is for development of system integrator who is familiar with Telnet to enable / disable the function and to setup its port .

BACnet <small>Beta</small>	
Enable	<input type="checkbox"/>
Port	47808
<input type="button" value="Apply"/>	

4.5.4 IP Service

- In this section, user can setup
- A. IP Server setting(Search)
 - B. CNT2 (MQTT)

IP Service Setting (Search)	
Enable	<input checked="" type="checkbox"/>
IP Service Server :	Server1 ▾
Device Name :	IP_POWER
Country :	Country
City :	City
myipedit login Account	
Find IP_POWER device on myipedit.com	
<input type="button" value="Apply"/>	

CNT(MQTT) Setting (Remote control)	
MQTT Service	IPPower ▾
Enable	<input checked="" type="checkbox"/>
Status	Connected
<input type="button" value="Apply"/>	

A. IP Service & CNT Setting :

The IP SERVICE allow 9828-P to be accessed easily on the internet by our IP Power Center or IPEDIT. With this feature anyone can find its device with no problems.

IP Service Server: Allows user can find user of 9828-P on the internet without having to remember long IP Addresses. Instead user can just remember the name of user device.

IP Service Setting (Search)	
Enable	<input checked="" type="checkbox"/>
IP Service Server :	Server1
Device Name :	IP_POWER
Country :	Country
City :	City
myipedit login Account	
Find IP_POWER device on myipedit.com	
<input type="button" value="Apply"/>	

- Enable : Enable or Disable this function by clicking the small box .
- IP Service Server : Custom – the server setting by yourself
Server 1- the server from our company
- Device name , Country & City :

User can search the 9828-P by Device name , Country or City.

This allows the device to be accessed easily on the Internet, user no longer have to Port Forwarding , user device to be able to use it. Only some devices are CNT compatible.

Please refer page #14 for the function of IP Server

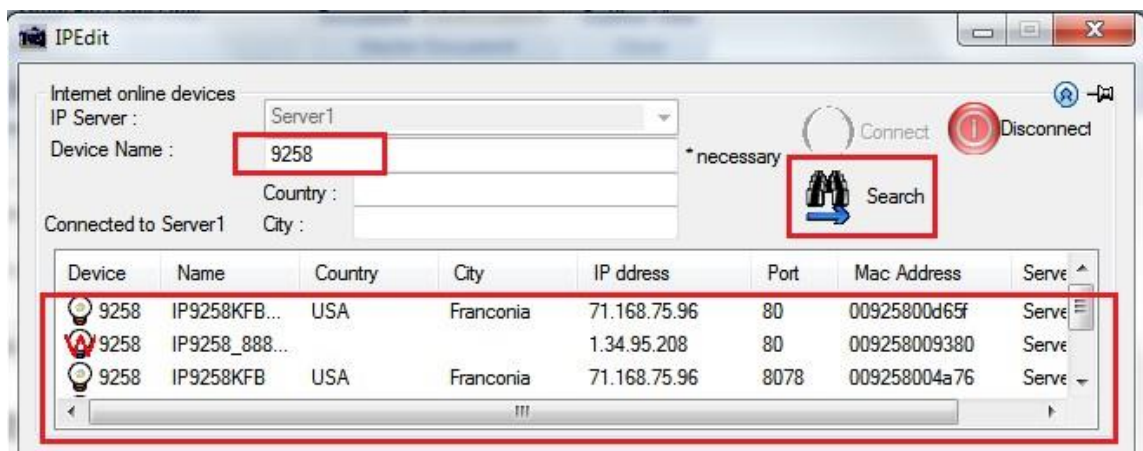

B. CNT (MQTT) –

For developing only. 9828-P supports MQTT function. Please contact with your distributor for the details if you would like to develop own system.

CNT(MQTT) Setting (Remote control)	
MQTT Service	IPPower ▾
Enable	IPPower
Status	Custom
	Google
	Azure
	AWS
	Apply

4.6 System Setting

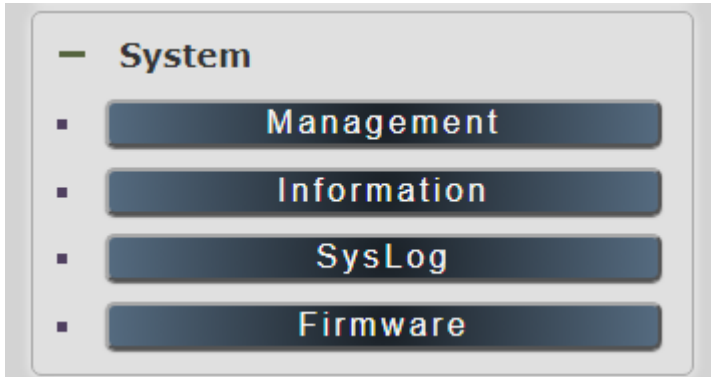

4.6.1 Management

In this section there are 6 settings: Administrator setting, Language Settings, Web server Setting, NTP settings, Import Configuration files and System Reset.

System Management

You may configure administrator account and password, NTP settings, and Dynamic NTP settings here.

Administrator Settings	
Account	<input type="text" value="admin"/> <input checked="" type="radio"/> Admin <input type="radio"/> Operator <input type="radio"/> Viewer
Password	<input type="password" value="*****"/> <input type="button" value="Apply"/>

Language Settings	
Language	<input type="text" value="English"/> <input type="button" value="Apply"/>

Web Server Settings	
Https(Port:443)	<input checked="" type="checkbox"/>
Http	<input checked="" type="checkbox"/>
Enable Self Signed Certificate	<input type="checkbox"/>
<input type="button" value="Apply"/>	

NTP Settings	
Date	<input type="text" value="01"/> / <input type="text" value="01"/> / <input type="text" value="1970"/> (MM/DD/YY)
Time	<input type="text" value="08"/> : <input type="text" value="49"/> : <input type="text" value="08"/> (HH:MM:SS) <input type="button" value="Apply"/>
Current Time	<input type="text" value="Thu Jan 1 08:49:08 GMT 1970"/> <input type="button" value="Sync with local time"/>
Time Zone	<input type="text" value="(GMT+0800)ChinaCoast,HongKong"/> <input type="button" value="Apply"/>
NTP Server	<input type="text" value="pool.ntp.org"/> ex: time.nist.gov
Sync with NTP	Every <input type="text" value="1"/> hours <input type="button" value="Apply"/>

Import configuration files	
Location	<input type="text" value="選擇檔案"/> <input type="button" value="沒有選擇檔案"/> <input type="button" value="Import"/>

System reset	
Export configuration file	<input type="button" value="Apply"/>
Factory Reset	<input type="button" value="Apply"/>
Reboot	<input type="button" value="Apply"/>

Administrator setting

In this section allows user to change password for 3 different authorization level . The account name and password can be changed , but each Authorities only support one Account name & one password.

Administrator: The *Administrator* has the authority to create other users, remove users, and control the device. 9828-P will ask to log in again if change the Default Setting here.

Operator : The operator can only control the setting of “ IO Control “ section but can not see other page of 9828-P .

Viewer: The viewer can only see the “ IO Control “ section , but can not see other page of 9828-P.

Default Setting of the Authorities :

Authority	Account name	Password
Admin	Admin	12345678
Operator	user	user
Viewer	guest	guest
Note	Please amend the password as number or English character from 1 to 8 characters. Do not use special symbol like “ ” ; : ~ ! @ # \$ % ^ & * ()	

Please click “Apply “ button after change the account name / password

Langrage Settings

There are 3 language option of 9828-P .The default langrage is English.
The other two languages are “Traditional Chinese “ and “ Simple Chinese “ .

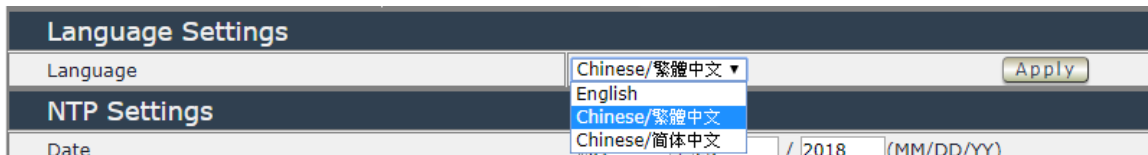

Web Server Settings

There are 3 options to setting Web server. (1) http (2) https (3) self-signed certificate
Http and Https are quite simple, just click on the icon to enable or disable it.

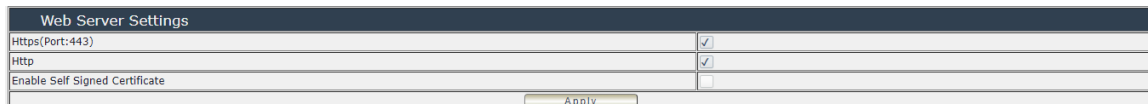

If you click the self-signed certificate, it will show two options of the certificate we provide, Choose the certificate you want in one of the options.

NTP setting

In this section , user can setup the date , time , current time , time zone , NTP server and sync with NTP to get the time synchronization .

NTP Settings	
Date	01 / 23 / 2018 (MM/DD/YY)
Time	14 : 49 : 22 (HH:MM:SS) <input type="button" value="Apply"/>
Current Time	Tue Jan 23 14:49:21 GMT 2018 <input type="button" value="Sync with local time"/>
Time Zone	(GMT+0800)ChinaCoast,HongKong
NTP Server	pool.ntp.org ex: time.nist.gov
Sync with NTP	Every 1 hours <input type="button" value="Apply"/> <input type="button" value="Cancel"/>

SYNC with NTP : User can setup the time gap (1~300 hours) for 9828-P to check the time with the NET server .

Import configuration files

To setup multiple with same setting , user can import the settings of other 9828-P from a “ DAT “ file which is exported form another 9828-P . By import this file to other 9828-P device and shorten the setup time .

Import configuration files	
Location	<input type="button" value="選擇檔案"/> 未選擇任何檔案 <input type="button" value="Import"/> <input type="button" value="Cancel"/>

As press “ Import “, there is caution message show as following :

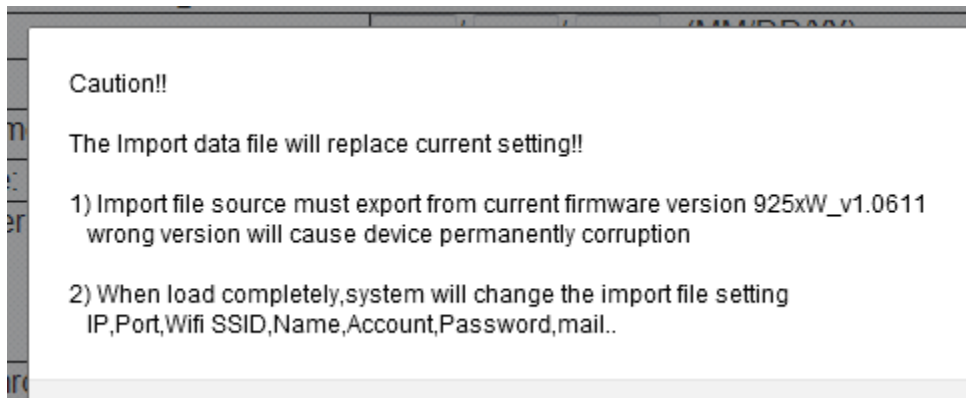

Before click “ Ok “ to import , please do read following notice :

- Do NOT import DAT file which is not export form 9828-P. The warranty will be invalided if anywrongdoing from “ Import “ .
- Please do Import the file in LAN / Ethernet . To avoid Import fail , please do not Import file vialnternet

System Rest

User can click one button to set back the setting to default or restart the 9828-P without device nearby user side.

Note : The factory default setting of 9828-P IP is assigned by DHCP. It will change the IP if load factory defaults .

System reset	
Export configuration file	<input type="button" value="Apply"/>
Factory Reset	<input type="button" value="Apply"/>
Reboot	<input type="button" value="Apply"/>

- Export configuration file : Export the settings into DAT file for import to other 9828-P
- Factory Reset : set back to factory default .
- Reboot : 9828-P device power reboot

4.6.2 System Information

User can get the system information here.

System Information			
System			
System Up Time	0 days 19 hour 44 min 20 sec	MAC Address	00:76:28:00:10:D8
Firmware Version	v1.31_788	Hardware Version	IP9828V1022
WAN			
WAN IP Address	36.224.143.224	Ethernet Port	80
Default Gateway	10.33.122.1	Internet Port	80
Primary DNS	168.95.1.1	Secondary DNS	8.8.8.8
LAN			
Connected Type	STATIC		
Local IP Address	10.33.122.12		
Local Netmask	255.255.255.0		
VPN			
IP Address	0.0.0.0		
Other Information			
SNMP	Disable		
ModBusTCP	Disable		
BacnetIP	Disable		
Telnet	Enable		
UPNP	Disable		
IPSERVICE(Search)	Enable		
CNT(Remote control)	Enable		
Http	Enable		
PPTP	Disable		

4.6.3 System Log

In this section , user can get the 9828-P system operation information and send the information to assign Server IP address (not support name) . **The system information will be deleted after 9828-P device power reboot.**

System Log	
Syslog:	
Syslog Server IP Address	<input type="text"/> <input type="button" value="Apply"/>
<input type="button" value="Refresh"/>	<input type="button" value="Clear"/>
System Log:	
<pre> Jan 23 18:16:04 IP_POWER syslog.info syslogd started: BusyBox v1.12.1 Jan 23 18:16:04 IP_POWER kern.notice kernel: klogd started: BusyBox v1.12.1 (2017-12-07 01:17:44) Jan 23 18:16:04 IP_POWER kern.alert kernel: [9.016000] PROC INIT OK! Jan 23 18:16:04 IP_POWER kern.err kernel: [9.780000] gre: can't add protocol Jan 23 18:16:04 IP_POWER kern.err kernel: [19.024000] ### raeth: can not open udhpcp_eth.pid </pre>	

Please click the IP and save by click “ Apply ”

4.6.4 Firmware

Please only use the file supply from Aviosys distributor or Aviosys.

There are two sections: Bootloader & Firmware

The firmware update function only support in LAN connection.

Before update, please DO [READ](#) THE HI-LITE MESSAGE BLOW:

Bootloader: This function is about to update hardware and control driver, it works with firmware but not change all the time.

It takes about 1 minute to upload upgrade flash and be patient please. Caution! A corrupted image will hang up the system.

AVIOSYS

Upgrade Firmware

Upgrade selected firmware to obtain new functionality. **Caution! A corrupted image will hang up the system.**
It takes about 1 minute to upload & upgrade flash and be patient please.

Version: Old

Update Bootloader

Location: 選擇檔案 未選擇任何檔案

Apply

Firmware

Location: 選擇檔案 未選擇任何檔案

Apply

To update the 9828-P, please follow the instruction below to prevent anything happens like **update incomplete** or **hardware disable** which may be caused by wrongdoing of updating:

- 1) Turn off all chat programs including (Skype, FB, QQ, AIM, Yahoo messengeretc.)
- 2) Check to make sure that all devices are turned on safely and powered
- 3) While updating do not turn off the power
- 4) Make sure that the cable is connected firmly
- 5) Do not interrupt the update process, the update must be completely finished .
- 6) Turn off, any Spyware or antivirus software which may conflict with the update.
- 7) Update firmware in the Local Area Network (LAN)
- 8) Support update under 32bit Web Browser (32 bit version only) like IE, Google Chrome,
Do not use browser at 64 bit version
- 9) Please change the PORT as 80
- 10) **Reboot and Do the Hardware Reset** (keep pressing RESET button for 10 secs) after update successfully.
- 11) **Clear the Cookies from the temporary file of PC** to avoid get the old webpage .

Please also update the notice in webpage before update:

5. Other ways to control

Besides HTTPS/CGI command and Telnet we supply here, 9828-P also support SNMP (MIB) , Modbus/TCP and BACnet /TCP . Please check page #47 to check and enable the function.

5.1 CGI HTTP Commands

CGI Commands allow you to easily integrate the 9828-P with other systems and programs. Pleaseread the instructions carefully on how to use the Http:// Commands

To use http:// Commands open up a web browser and type in the command that you would like to use.

1. User authorization .There are 3 formats :

For example : IP address 192.168.1.18 , Username : admin. Password : 12345678

1.1 <http://admin:12345678@192.168.1.18/set.cmd?cmd=getpower>

1.2 <http://192.168.1.18/set.cmd?user=admin+pass=12345678+cmd=getpower>

The above 2 way also for HTTPS

2. Command

set.cmd?cmd=

All command do not separate capital / lower case , the connect symbol between commands can be “+” , “&” and “?”.

2.1 To get firmware version : getversion

<http://192.168.1.18/set.cmd?cmd=getversion>

System return :

```
<!--CGI-DATABEG-->
```

```
<p>
```

```
Version=v1.09_418</p>
```

```
<!--CGI-DATAEND-->
```

2.2 To get MACaddress: getmac

<http://192.168.1.18/set.cmd?cmd=getmac>

System return:

```
<!--CGI-DATABEG-->
```

```
<p>
```

```
mac=007628000284</p>
```

```
<!--CGI-DATAEND-->
```

2.3 To get the status of power on/ off: `getpower`

<http://192.168.1.18/set.cmd?cmd=getpower>

System return:

CGI Command : Data follows

p61=0, p62=0

P61 to P62 means : POWER1 to POWER2

2.4 To set the power on / off : `setpower&p6x=0` or `1`

p6x=0 means off, p6x=1 means ON, x can be 1 to 2 (power1 to power 2)

Example : Turn on POWER1 and turn off POWER2:

<http://192.168.1.18/set.cmd?cmd=setpower&p61=1&p62=0>

System return: CGI Command : Data follows

p61=1,p62=0,p63=0

2.5 Setup power to reboot as RESET: `setpowercycle& p6x=delayTime`

X can be 1 to 2 (power 1 to power 2) , ; dealyTime mean the time (second) waiting for reset

For example :

<http://192.168.1.18/set.cmd?cmd=setpowercycle&p61=5&p62=2>

System return: CGI Command : Data follows

p61 cycle ok,p62 cycle ok

2.6 Get current Amp value : `getcurrent`

For example :

<http://192.168.1.18/set.cmd?cmd=getcurrent>

System return:

```
<!--CGI-DATABEG-->
```

```
<p>
```

```
c61= 0.0, temp=28.3</p>
```

```
<!--CGI-DATAEND-->
```

5.2 Telnet Control

Please enable the telnet function in “Application “ → “ Communication

“Or Check page #47 to check and enable the function .

TELNET:	
Enable	<input checked="" type="checkbox"/>
<input type="button" value="Apply"/>	

```
C:\ Telnet 192.168.1.18
IP login: admin
Password:
```

```
C:\ Telnet 192.168.1.18
#
# ioctrl -h
**-----**
Usage: ioctrl
[-h ! --help l.....: display this help
[-s ! --setpower p6=0011 or p6x=1(x=1,2,3,4)l.....: turn on/off ports on the d
evice
[-p ! --getpower l...: get the on/off status of the device
[-c ! --current l.....: get the current value of the device
[-t ! --temp l.....: get the temperature value of the device
[-v ! --version l.....: display version information
-----
# ioctrl -s p6=1111
p61 ok,p62 ok,p63 ok,p64 ok,
# ioctrl -c
Current value: 0.000000, 0.000000, 0.000000, 0.000000
# ioctrl -t
Temperature value: 32.299999
# ioctrl -v
IO CONTROL Version: 1.0
Compilation Date....: May 14 2013
Compilation Time....: 10:44:47
# ioctrl -p
Power Status: 1, 1, 1, 1
#
```

Notice: The command “ -C “ & “ -T “ are for models 9828-P only.

6. FAQ :

Q1: Why can't I see the 9828-P's IP address in IPEDIT.exe

Ans.:

Please check if your 9828-P had boot up successfully . There is a short beep sound to show 9828-P boot up successfully after device power up for 45 second.

There are several possibilities for this issue as 9828-P boot up successfully :

1. Segment of your PC :

Please check the PC you use is under same LAN/ network / segment as 9828 .

2. Firewall / Antivirus protection :

Please turn off some Anti-Virus / online chatting software .

3. Network card :

IPEDIT can only work for the PC with one network card . If there are more than 1 network card , include dynamic network card , please disable one and make sure the one you selected is Under the same segment with IP9828-P

4. Connection sequence

9828-P will stay DHCP mode – keep waiting for your router to assign the IP (DHCP) - if you connect the 9828-P to PC directly and connect to network cable before the power of 9828-P device turn on .

If connect to PC directly , please wait for the boot up beep first and then connect the network cable to your PC . And the IP should be fixed at 192.168.100.169

Q2 : Why can't I see my 9828-P after arrange the port forwarding in my router?

Ans : Please make sure the Network Type (Gateway) is correct - LAN or WAN .

Q3 : Why can't I receive e-mail ?

Ans: Please check the DNS and GATEWAY setting first (Check user router or ask user ISP company). There is a test button for checking the setting success or fail to send e-mail.

Login From 192.168.100.26 connect to Ethernet 192.168.100.28



Notice :

Under DHCP mode - 9828-P will get the Network type (Gateway) information automatically. But if under Static mode , please do fill up the correct Network type (gateway).

Step 3 : Connect user PC and 9828-P to a router by LAN. Then **reboot 9828-P (MUST DO)** . After 45 seconds with a long beep sound , user can find the LAN IP of 9828-P by IPEDIT.exe

Q4: How can I reset to default:

Ans : Keep pressing the button of "RESET for 7 seconds and then release it.

To reset to original manufacture settings : press the reset button with a sharpen pin for 7 seconds then RELEASE. There will be total 4 beeps sound which means reset start and 9828-P will be rebooted itself -there is one beep after reboot) and most information go back to default setting (LAN IP)

